

● **MONORAIL**
THE REVOLUTION OF
URBAN TRANSIT

Scomi's Monorail system is designed to address current mass urban transportation needs. The system complies with international standards of safety, quality and reliability. Based on our technological innovation, the monorail offers features and benefits for optimum flow of passengers, and vehicle management system components that enables:

- A smooth ride quality
- Higher passenger capacity
- Energy efficiency
- Lower operating costs
- Environmentally friendly transportation needs
- Futuristic designs



● Designed for Optimum Flow of Passengers

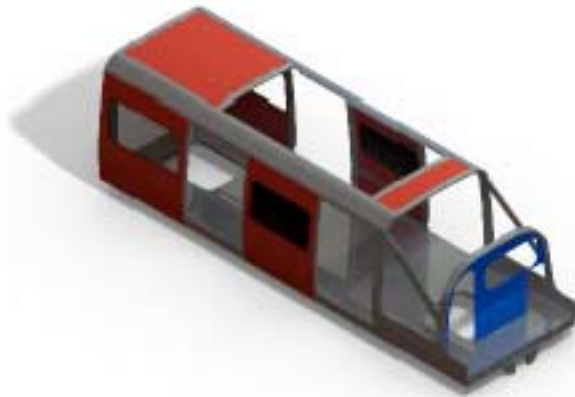

CARBODY STRUCTURE

The monocoque (load-bearing single-shell frame) body structure is constructed with aluminium extrusion materials. Its lightweight structure combined with the aluminium apron structure provides enhanced strength and durability of up to 30 years.

INTERIOR FACILITIES

The interior is designed with the comfort and safety of passengers in mind. Its spacious, minimalist concept maximises the flow of passengers and minimises obstruction in and around the doorways.



- Rail and stanchions are designed to assist safe boarding, on-board circulation, seating, standing and alighting assistance, including for persons with disabilities.



- Handrails and handgrips are placed within easy reach of all standing passengers.



- The air conditioned passenger saloon is designed with ergonomic mass transit seats and two adjacent flippable seats combined with the disabled wheelchair area, which optimises standing area and comfort.



- Slip-resistant flooring keeps passenger-footing firm and stable.

● Vehicle Management System

VEHICLE MANAGEMENT SYSTEM (VMS)

The VMS provides supervisory control, monitoring and diagnostic systems.

Train status information is graphically displayed to the operator via the HMI panel. Its user-friendly interface display allows the operator to quickly respond and understand all train systems status.

The annunciation of train system status and abnormal conditions are categorised and displayed in real time, and prioritised in order of critical system hierarchy. As an option, critical data can be logged for further analysis.



BRAKE SYSTEM

The brake system comprises the latest generation electro-pneumatic mechatronic system available. Cost-effective, modular and lightweight, it provides multiple functionalities including high integrity emergency brakes, service brakes (blended where necessary), security brakes and parking brakes.

The system is configurable with ATO / ATP railway applications, and provides valuable cost and weight savings. Additional functions include compressor control, communications with train management system, self-diagnosis, wheel slip and slide control with dual bus communication between bogies and individual cars.

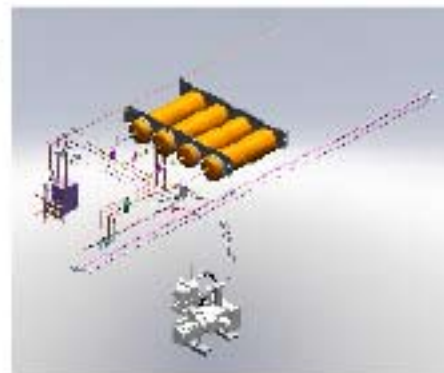

CAB FACILITIES

The driver's console incorporates the master controller assembly, control buttons and panel view. The master controller controls the propulsion and braking systems, and is equipped with a Drivers' Vigilance Device (DVD) control, which prevents vehicle movement without positive manual actuation by the operator.

An ergonomic console design, combined with a pneumatic seat suspension maximises reach of the controls and panel-view interface while enhancing driver-comfort and providing an optimal field of vision. The air-conditioned driver's compartment also carries emergency safety equipment.



ATP / ATO EQUIPMENT

Provision has been made to install automatic train protection systems and, if required, automatic train operation equipment. The design of the safety circuits and communication with the vehicle management system is also taken into consideration.



BOGIE

The bogie structure is designed to support static and fatigue loads for as long as 30 years. To provide a smooth ride, the straddle-type bogie design features full vertical pneumatic and shock absorbers suspension, and a progressive stiffness lateral suspension. Its traction system is connected to the axle through CV joint shafts.



AUTOMATIC COUPLER

The mechanical coupler at each end is capable of emergency mechanical connection, as well as impact energy absorption. It is capable to accommodate horizontal and vertical curves, as well as any special track work.

The retractable coupler is hidden inside the vehicle nose during normal operations. A deployment mechanism opens a cover and extends the coupler for coupling purpose whenever required.

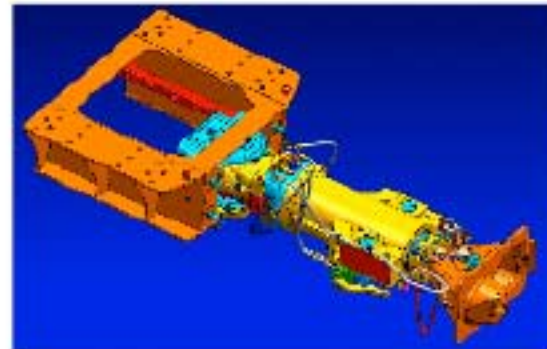

VVVF (VARIABLE VOLTAGE VARIABLE FREQUENCY) DRIVES

Current technology PWM AC Drive / Dynamic brake controllers is certified to the applicable IEC & NFPA codes / standards, which are the selected choice for the propulsion system.

Fine tuned for smooth acceleration / deceleration, it gives high standards of passenger-comfort. Its high torque and duty cycle capabilities also make it suitable for passenger transit applications.

Power: 170 kW

Voltage Applications: 500 to 1000 Vdc

Mode of Control: Field-oriented Control PWM

Speed Regulation: 0.001% with Feedback



PROPULSION CONTROL EQUIPMENT

The propulsion equipment uses VVVF inverters with high power per weight ratio. The system also provides high reliability and safety integrity, featuring safe-off state interlock with the braking system. It is also equipped with a dual-media redundant network interfaced to the VMS.

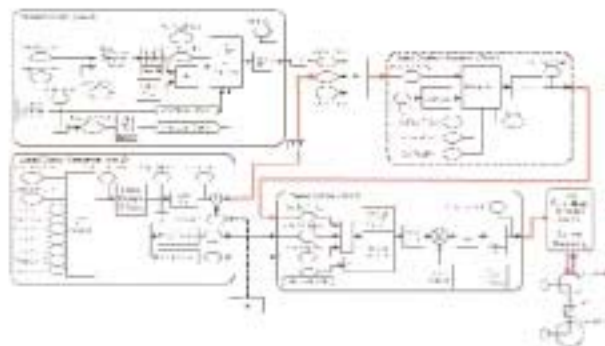

SPECIFICATIONS

VEHICLE DATA

Type of Vehicle

Monorail with single axle bogie
(straddle type)

Train Consist

2 / 4 / 6-car train

DIMENSIONS AND WEIGHT

Guidebeam Running Surface Width

690 – 800 mm

Length of Train

2-car 23.7 m

4-car 45.3 m

6-car 67.0 m

Overall Width Including Doors

3.08 m

Overall Height

4.72 m

Top of Beam to Top of Car

3.46 m

Top of Beam to Top of Floor

800 mm

Doorway Width

(clear opening)

1.50 m

Doorway Height

(clear opening)

1.95 m

Floor to Ceiling Height

2.10 m

Wheel Diameter New

1.00 m

Wheel Diameter Worn

0.99 m

Wheel Base

(bogie-to-bogie)

7.0 m

AWO Car Weight (empty)

13,000 kg

TECHNICAL CHARACTERISTICS

Train Control

ATP (upgradable to ATO)

Power Collection

Positive / negative dual rail supply
collection system

Primary Power

Nominal line voltage 750 Vdc

Auxiliary Power Supply

415 / 240 Vac

Low-voltage Power Supply

24 Vdc / 110 Vdc

Propulsion

Electrical motor & gear reducers

Service Braking

Electrodynamic regenerative with
pneumatic disc brakes

Parking Brakes

Spring applied disc brakes

Emergency Brakes

Electrodynamic regenerative with
pneumatic disc brakes

Automatic Couplers

Mechanical retractable coupler

Bogie Material

Steel

Vertical Suspension

Pneumatic air bags and shock absorbers

Load Tyres

Metro-type nitrogen filled with internal
run-flat and pressure monitoring sensor

Guidance Tyres

Metro-type nitrogen filled with internal
run-flat

Carbody

- Lightweight aluminium extrusion
- Aluminium apron structure

Side Windows

6 per car, laminated / tempered glass

Doors

4 per car, biparting, external sliding

Air Conditioning

1 x 36 kW roof mounted unit per car

Fire Safety Design

NFPA 130 compliant

PERFORMANCE AND CAPACITY

Acceleration Rate (service)

1.1 m / s²

Braking Rate (service)

1.0 m / s²dynamic

1.0 m / s²pneumatic

Braking Rate (emergency)

1.1 m / s²dynamic

1.1 m / s²pneumatic

Maximum Design Speed

90 km / h

Maximum Operating Speed

Up to 80 km / h

Minimum Horizontal Radius

50 m

Minimum Vertical Radius

500 m

Maximum Sustained Gradient

6%

Buff Load

400 kN

Seated Passengers

20 per car

Capacity per Car

20 seats

54 @ 2 pass. / m²

96 @ 4 – 5 pass. / m²

139 @ 7 pass. / m²

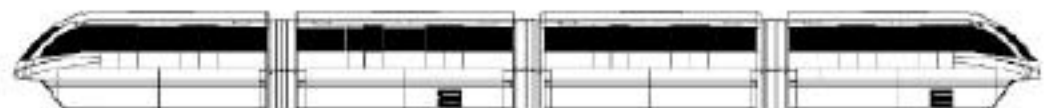

Scomi[®]

Scomi Rail Bhd 

5th Floor, Wisma Chase Perdana

Off Jalan Semantan

Damansara Heights

50490 Kuala Lumpur

Malaysia

www.scomiengineering.com.my

T +603 2080 5080

F +603 2080 6328

E info@my.scomiengineering.com
